

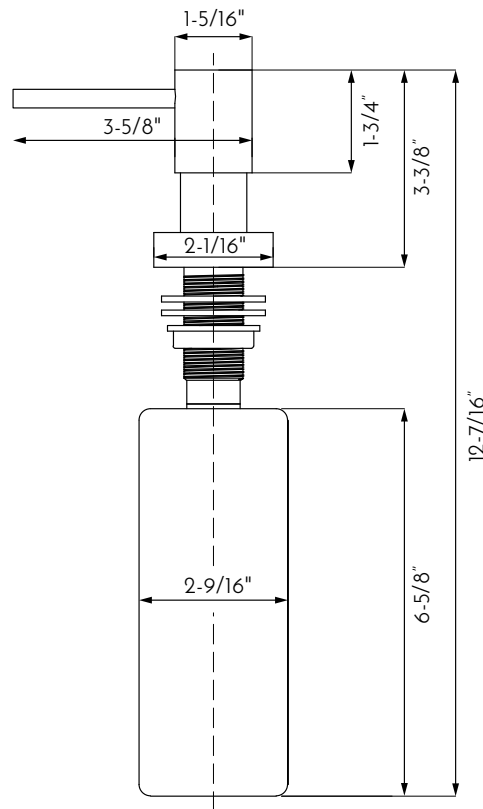

DAX-1001-BN



SOAP DISPENSERS **SERIES**



FEATURES

- Brass head
- Brushed nickel finish





01



02

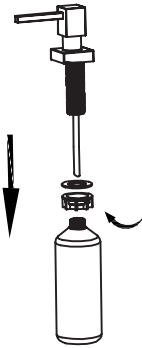

Remove locknut and thread bottle, leaving washer on threaded flange.

03

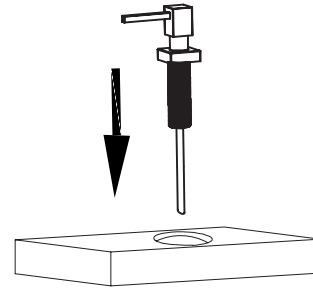

Insert flat end of pump tube into pump.

04

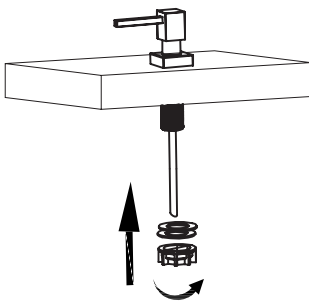

From underneath sink hand tighten the locknut to secure flange.

05

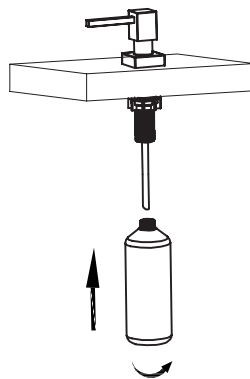

Locknut to thread bottle.

06

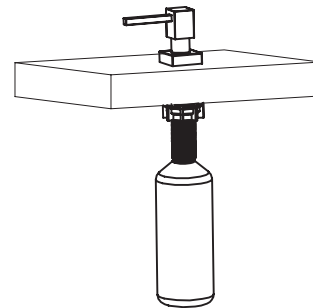



SOAP DISPENSER **DAX-1001-BN**

MODEL	DAX-1001-BN
MATERIAL	Brass head
SHAPE	Square
DEPTH	6-5/8"
HEIGHT	12-7/16"
LENGTH	2-9/16"
WEIGHT	0.661387 lb
WIDTH	3-5/8"
FINISH	Brushed nickel
INSTALLATION TYPE	Deck Mount

For parts or sale requirements
please contact our customer service department:



CS@daxib.com



1 888 685 8236